

innovative

SIT-STAND



OCTOBER 2019

Our sit-stands help
improve wellness
and productivity by
converting any desk into
a standing desk.

Sit-Stand



Winston Desk 2 - 36"



Winston Desk Corner - 36"



Winston Lift Single



Winston Lift Dual



Winston Workstation Single



Winston Workstation Dual



Winston Workstation Triple



Winston Workstation Quad



Winston-E Single



Winston-E Dual



Winston-E Triple



One Touch Single



One Touch Dual



One Touch Triple



One Touch Quad



One Touch 2 over 2



One Touch 3 over 3



Anti-Fatigue Mat



Mounts



Laptop Holders

Winston Desk instantly transforms any tabletop into a standing desk.

Available in:
Black

Winston Desk®

6

Winston Lift is an arm-based sit-stand that features a wide range of movement – perfect for collaborative workspaces.

Available in:
Flat White
Silver
Vista Black

Winston Lift™

10

Winston Workstation offers an expansive work surface and is engineered with a locking cylinder for impressive stability.

Available in:
Flat White
Silver
Vista Black

Winston Workstation®

14

Winston-E is an electric powered sit-stand loaded with premium features including programmable sit and stand memory and focal depth adjustment.

Available in:
Gray Duotone

Winston-E®

20

One Touch is a highly configurable, electric powered sit-stand workstation system.

Available in:
Silver

One Touch

24

Create the perfect sit-stand with our helpful accessories.

Accessories

30



Winston Desk®

The Winston Desk is an ultra easy sit-stand solution. Designed with an upper display surface and lower, retractable keyboard and mouse desk. Winston Desk features a gas-assisted lift mechanism that lets you switch easily between sitting and standing in just a few seconds. It also holds up to 35 lbs, while staying steady and solid at any height. Winston Desk ships fully assembled and ready-to-use – just put it right on top of your current desk, and you're ready to work.

Winston Desk Features



Retractable Lower Work Surface

Lower work surface retracts to allow for a comfortable position.



Easy Height Adjustment

Gas-assisted lifting makes sitting and standing transitions a breeze.



Choose Your Own Height

Seamless height adjustment means there are no pre-determined height settings, Winston Desk locks in place at the height you want.



Optional Monitor Arm Mounting

Upper desk surface has a .5" bolt-thru hole and a reinforced edge for mounting an optional monitor arm with a thru-desk or clamp mount.

Winston Desk®



Winston Desk 2 - 36"

List Price **\$639**

SPECIFICATIONS

Height Adjustment Mechanism: Pneumatic
Screen Size: Up to 34"
Height Adjustment: 13.5"
Mount Configurations: Freestanding
Warranty: 5 Years

AVAILABLE MODELS

WNST2-DESK-36 Supports up to 35 lbs (15.8 kg)

FINISHES

BLK BLACK



Winston Desk Corner - 36"

List Price **\$716**

SPECIFICATIONS

Height Adjustment Mechanism: Pneumatic
Screen Size: Up to 34"
Height Adjustment: 13.0"
Mount Configurations: Freestanding
Warranty: 5 Years

AVAILABLE MODELS

WNST-DESKCR-36 Supports up to 35 lbs (15.8 kg)

FINISHES

BLK BLACK

CAPABILITIES (WINSTON DESK 2)

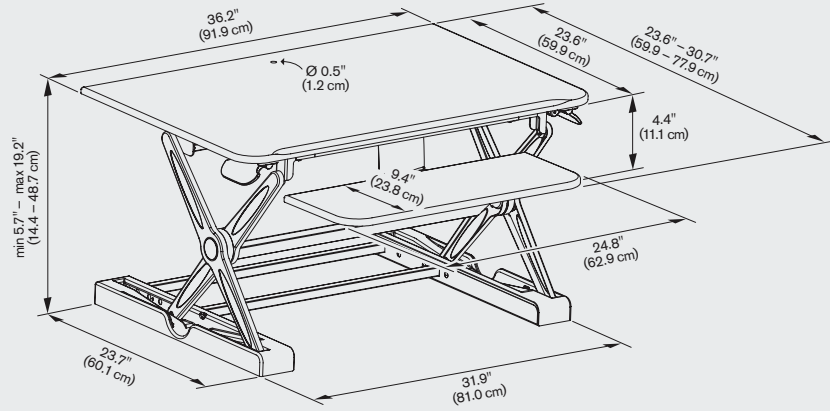

CAPABILITIES (WINSTON DESK CORNER)

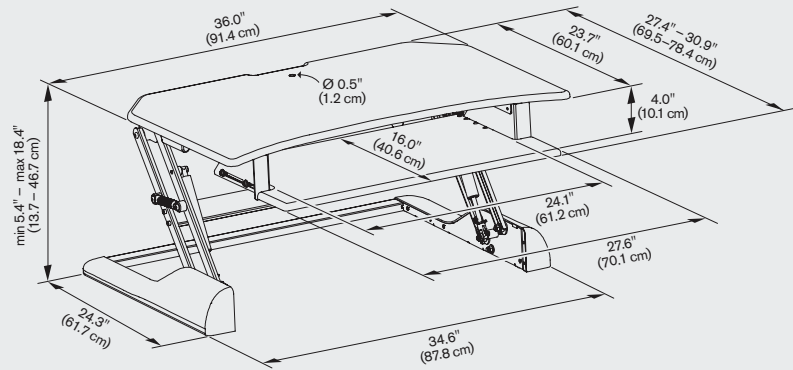



Winston Lift™

Winston Lift is an arm-based sit-stand product that allows users to turn their desk into a healthier, more dynamic workstation. Featuring an adjustable keyboard platform, quick-release stability lever, and textured wood grain surface, Winston Lift is the perfect combination of thoughtful design and functionality.

Winston Lift Features



Flexible Monitor Movement

Winston Lift is an arm based sit-stand offering maximum flexibility for monitor positioning, allowing you to easily share your screen.



Improves Workplace Wellness

Intuitive height adjustment allows workers to easily transition from sitting to standing throughout the day, promoting well being and productivity.



Engineered for Stability

The unique quick-release lever of the Winston Lift locks the arm's height position in place to prevent the work surface from drifting downward while computing.



Maximizes Your Workspace

Winston Lift's minimal footprint allows you to move it out of the way when not in use and regain access to your original work surface.

Winston Lift™



Winston Lift Single

List Price **\$650**

SPECIFICATIONS

Height Adjustment Mechanism: Pneumatic

Screen Size: Up to 30"

Height Adjustment: 19"

Extension Range: 34.5"

Mount Configurations: Desk Edge

VESA Compatibility: 75 & 100mm, adapter included

Warranty: 5 Years

AVAILABLE MODELS

WNST-LIFT-1

Supports up to 25 lbs (11.3 kg)

FINISHES

248 FLAT WHITE

124 SILVER

104 VISTA BLACK



Winston Lift Dual

List Price **\$725**

SPECIFICATIONS

Height Adjustment Mechanism: Pneumatic

Screen Size: Up to 30"

Height Adjustment: 19"

Extension Range: 34.5"

Mount Configurations: Desk Edge

VESA Compatibility: 75 & 100mm, adapters included

Warranty: 5 Years

AVAILABLE MODELS

WNST-LIFT-2

Supports up to 25 lbs (11.3 kg)

FINISHES

248 FLAT WHITE

124 SILVER

104 VISTA BLACK

CAPABILITIES (WINSTON LIFT SINGLE)

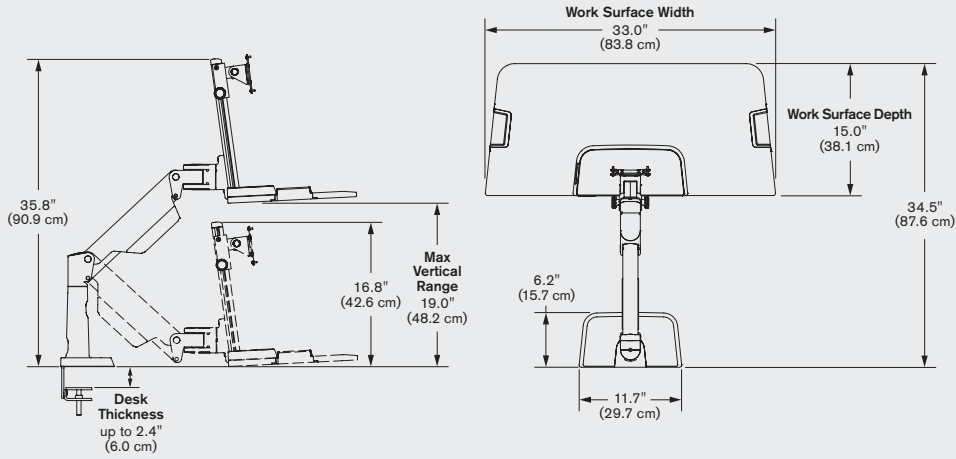

MOUNT

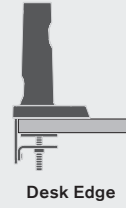

CAPABILITIES (WINSTON LIFT DUAL)

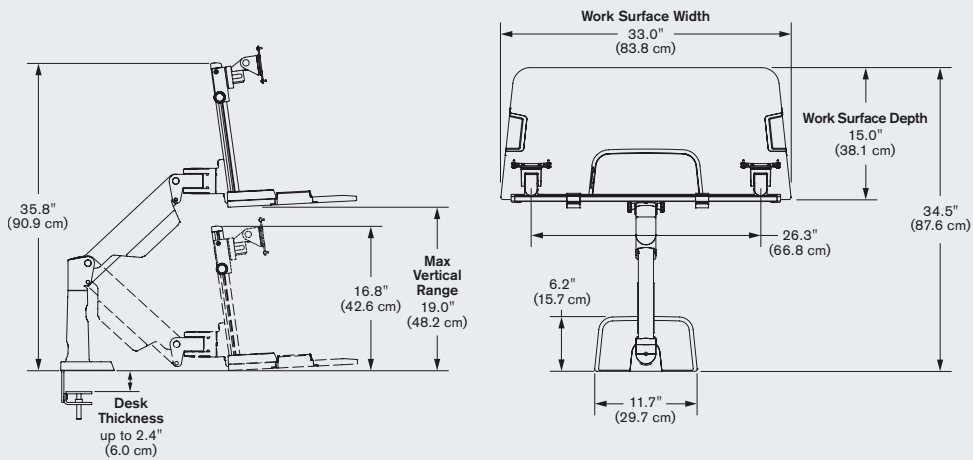

MOUNT





Winston Workstation®

Winston Workstation – Energizing your body. Inspiring your mind. Instantly converts any desk into a sit-stand workspace boosting health and productivity.

Winston Workstation Features



Moving at Work for a Healthy Lifestyle

Ease body pain and boost health by increasing your movement at work. Winston gives you the freedom to easily alternate between sitting and standing throughout the day.



Easy Height Adjustment

Adjust the height of your sit-stand workstation with just the push of a button. Features 17" of height adjust to accommodate a variety of users.



Expansive Work Surface

Large surface feels more like a real desk when standing and allows you to take all of your necessary items with you when you stand.



Engineered for Stability

The industry's first locking cylinder keeps your work space in place, eliminating wobble while you work.

Winston Workstation® | Compact Work Surface



List Price **\$1,019**

Winston Workstation Single | COMPACT

SPECIFICATIONS

Height Adjustment Mechanism: Pneumatic
Screen Size: Up to 43"
Height Adjustment: 17.1"
Mount Configurations: Freestanding, Desk Edge*, Thru-Desk*
VESA Compatibility: 75 & 100mm, adapter included
Warranty: 5 Years

AVAILABLE MODELS

WNST-1-CW Supports 7 - 20 lbs (3.2 - 9.1 kg)

FINISHES

124 SILVER
104 VISTA BLACK



List Price **\$1,072**

Winston Workstation Dual | COMPACT

SPECIFICATIONS

Height Adjustment Mechanism: Pneumatic
Screen Size: Up to 30"
Height Adjustment: 17.1"
Mount Configurations: Freestanding, Desk Edge*, Thru-Desk*
VESA Compatibility: 75 & 100mm, adapters included
Warranty: 5 Years

AVAILABLE MODELS

WNST-2-CW Supports 10 - 26 lbs (4.5 - 11.8 kg)

FINISHES

124 SILVER
104 VISTA BLACK

CAPABILITIES (SINGLE + DUAL COMPACT)

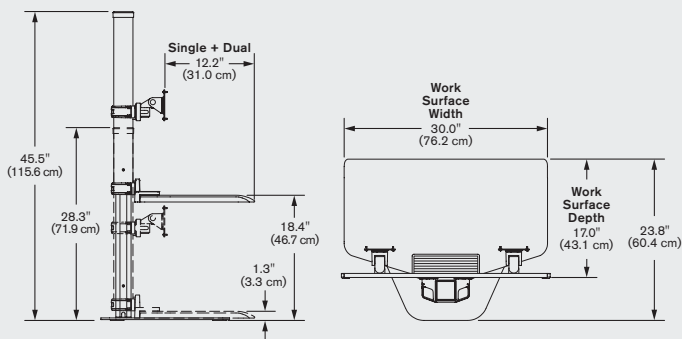

MOUNTS

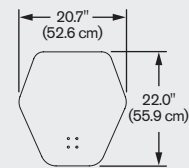

Freestanding Base

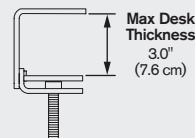

Desk Edge*
Model 8472

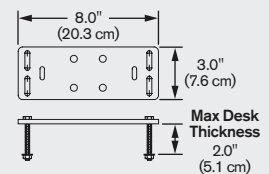

Thru-Desk*
Model 8485

* Sold separately.



List Price **\$1,282**

Winston Workstation Triple | COMPACT

SPECIFICATIONS

- Height Adjustment Mechanism:** Pneumatic
- Screen Size:** Up to 24"
- Height Adjustment:** 17.1"
- Mount Configurations:** Freestanding, Desk Edge*, Thru-Desk*
- VESA Compatibility:** 75 & 100mm, adapters included
- Warranty:** 5 Years

AVAILABLE MODELS

WNST-3-CW Supports 15 - 36 lbs (6.8 - 16.3 kg)

FINISHES

- 124** SILVER
- 104** VISTA BLACK



List Price **\$1,597**

Winston Workstation Quad | COMPACT

SPECIFICATIONS

- Height Adjustment Mechanism:** Pneumatic
- Screen Size:** Up to 24"
- Height Adjustment:** 17.1"
- Mount Configurations:** Freestanding, Desk Edge*, Thru-Desk*
- VESA Compatibility:** 75 & 100mm, adapters included
- Warranty:** 5 Years

AVAILABLE MODELS

WNST-4-CW Supports up to 24 - 40 lbs (10.9 - 18.1 kg)

FINISHES

- 124** SILVER
- 104** VISTA BLACK

CAPABILITIES (TRIPLE + QUAD COMPACT)

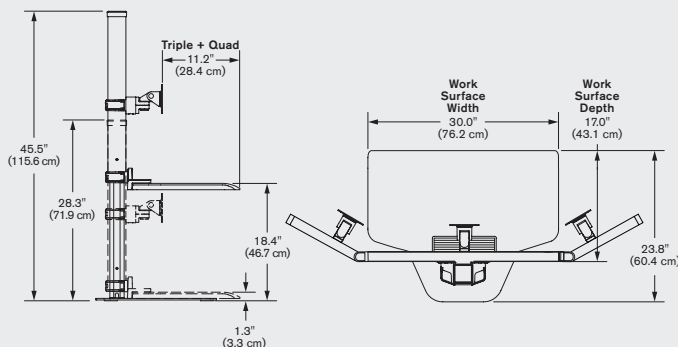

MOUNTS

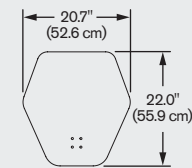

Freestanding Base

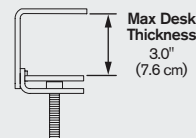

Desk Edge*
Model 8472

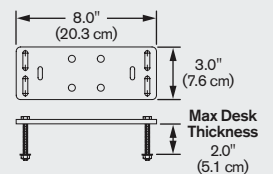

Thru-Desk*
Model 8485

* Sold separately.

Winston Workstation® | Standard Work Surface



Winston Workstation Single

List Price **\$1,019**

SPECIFICATIONS

Height Adjustment Mechanism: Pneumatic
Screen Size: Up to 43"
Height Adjustment: 17.1"
Mount Configurations: Freestanding, Desk Edge*, Thru-Desk*
VESA Compatibility: 75 & 100mm, adapter included
Warranty: 5 Years

AVAILABLE MODELS

WNST-1 Supports 7 - 20 lbs (3.2 - 9.1 kg)

FINISHES

248 FLAT WHITE

124 SILVER

104 VISTA BLACK



Winston Workstation Dual

List Price **\$1,072**

SPECIFICATIONS

Height Adjustment Mechanism: Pneumatic
Screen Size: Up to 30"
Height Adjustment: 17.1"
Mount Configurations: Freestanding, Desk Edge*, Thru-Desk*
VESA Compatibility: 75 & 100mm, adapters included
Warranty: 5 Years

AVAILABLE MODELS

WNST-2 Supports 10 - 26 lbs (4.5 - 11.8 kg)

FINISHES

248 FLAT WHITE

124 SILVER

104 VISTA BLACK

CAPABILITIES (SINGLE + DUAL)

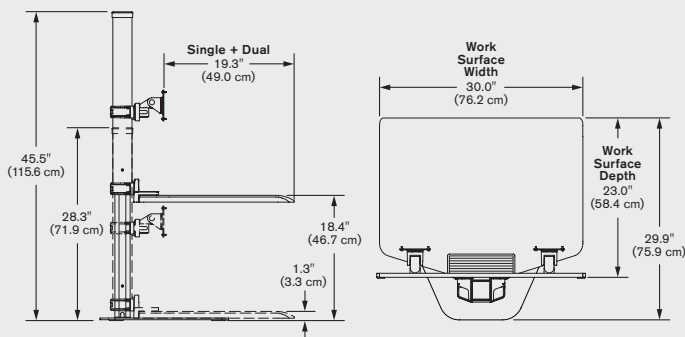

MOUNTS

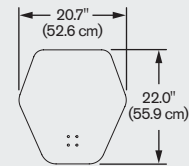

Freestanding Base

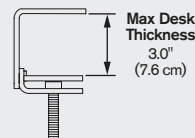

Desk Edge*
Model 8472

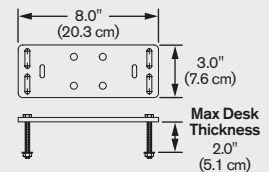

Thru-Desk*
Model 8485

* Sold separately.



Winston Workstation Triple

List Price **\$1,282**

SPECIFICATIONS

Height Adjustment Mechanism: Pneumatic
Screen Size: Up to 24"
Height Adjustment: 17.1"
Mount Configurations: Freestanding, Desk Edge*, Thru-Desk*
VESA Compatibility: 75 & 100mm, adapters included
Warranty: 5 Years

AVAILABLE MODELS

WNST-3 Supports 15 - 36 lbs (6.8 - 16.3 kg)

FINISHES

248 FLAT WHITE
124 SILVER
104 VISTA BLACK



Winston Workstation Quad

List Price **\$1,597**

SPECIFICATIONS

Height Adjustment Mechanism: Pneumatic
Screen Size: Up to 24"
Height Adjustment: 17.1"
Mount Configurations: Freestanding, Desk Edge*, Thru-Desk*
VESA Compatibility: 75 & 100mm, adapters included
Warranty: 5 Years

AVAILABLE MODELS

WNST-4 Supports up to 24 - 40 lbs (10.9 - 18.1 kg)

FINISHES

248 FLAT WHITE
124 SILVER
104 VISTA BLACK

CAPABILITIES (TRIPLE + QUAD)

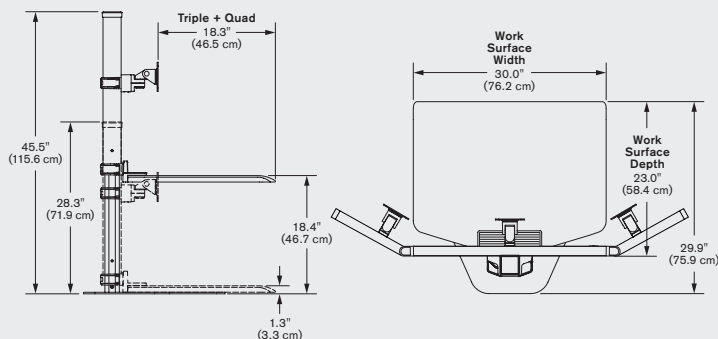

MOUNTS

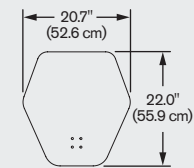

Freestanding Base

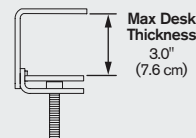

Desk Edge*
Model 8472

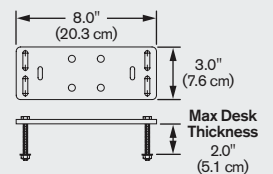

Thru-Desk*
Model 8485

* Sold separately.



Winston-E®

Winston-E is a responsive powered riser that takes the sit-stand conversation to a whole new level. The next-generation retrofit work surface with monitor arms is engineered for ease and freedom of movement. Fully loaded, we've thought of every detail for Winston-E so you're free to think about what's important to you.



Winston-E Features



Independent Monitor Height Adjustment

Ease body pain and boost health by increasing your movement at work. Winston gives you the freedom to easily alternate between sitting and standing throughout the day.



Focal Depth Adjustment

Adjust the height of your sit-stand workstation with just the push of a button. Features 17" of height adjust to accommodate a variety of users.

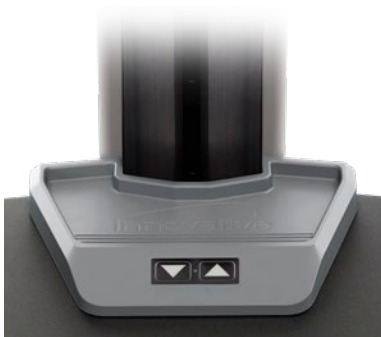

One-Touch Power: Set It and Forget It

With the touch of a button, power between sitting and standing height. Programmable control remembers your height for sit and stand.



Upping the Ante with Bold Style

Robust electronics encased in a sleek design with modern edges and clean lines.

Winston-E® | Compact Work Surface



List Price **\$1,513**

Winston-E Single | COMPACT

SPECIFICATIONS

Height Adjustment Mechanism: Electric
Screen Size: Up to 43"
Height Adjustment: 18.4"
Mount Configurations: Freestanding
VESA Compatibility: 75 & 100mm, adapter included
Warranty: 5 Years

AVAILABLE MODELS

WNSTE-1-CW Supports up to 40 lbs (18 kg)

FINISHES

270 GRAY DUOTONE



List Price **\$1,681**

Winston-E Dual | COMPACT

SPECIFICATIONS

Height Adjustment Mechanism: Electric
Screen Size: Up to 30"
Height Adjustment: 18.4"
Mount Configurations: Freestanding
VESA Compatibility: 75 & 100mm, adapters included
Warranty: 5 Years

AVAILABLE MODELS

WNSTE-2-CW Supports up to 40 lbs (18 kg)

FINISHES

270 GRAY DUOTONE



List Price **\$1,818**

Winston-E Triple | COMPACT

SPECIFICATIONS

Height Adjustment Mechanism: Electric
Screen Size: Up to 24"
Height Adjustment: 18.4"
Mount Configurations: Freestanding
VESA Compatibility: 75 & 100mm, adapters included
Warranty: 5 Years

AVAILABLE MODELS

WNSTE-3-CW Supports up to 40 lbs (18 kg)

FINISHES

270 GRAY DUOTONE

CAPABILITIES (COMPACT WORK SURFACE)

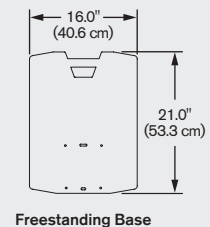
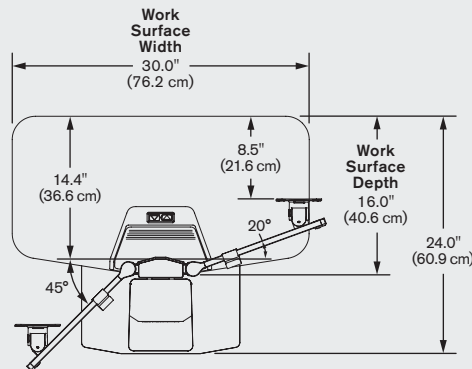
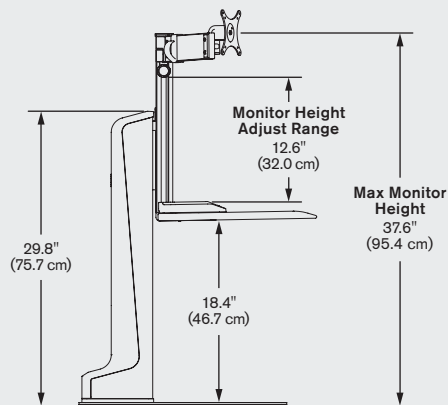

Standard Work Surface



Winston-E Single List Price \$1,513

SPECIFICATIONS

Height Adjustment Mechanism: Electric
Screen Size: Up to 34"
Height Adjustment: 18.4"
Mount Configurations: Freestanding
VESA Compatibility: 75 & 100mm, adapter included
Warranty: 5 Years

AVAILABLE MODELS

WNSTE-1 Supports up to 40 lbs (18 kg)

FINISHES

270 GRAY DUOTONE

Winston-E Dual List Price \$1,681

SPECIFICATIONS

Height Adjustment Mechanism: Electric
Screen Size: Up to 30"
Height Adjustment: 18.4"
Mount Configurations: Freestanding
VESA Compatibility: 75 & 100mm, adapters included
Warranty: 5 Years

AVAILABLE MODELS

WNSTE-2 Supports up to 40 lbs (18 kg)

FINISHES

270 GRAY DUOTONE

Winston-E Triple List Price \$1,818

SPECIFICATIONS

Height Adjustment Mechanism: Electric
Screen Size: Up to 24"
Height Adjustment: 18.4"
Mount Configurations: Freestanding
VESA Compatibility: 75 & 100mm, adapters included
Warranty: 5 Years

AVAILABLE MODELS

WNSTE-3 Supports up to 40 lbs (18 kg)

FINISHES

270 GRAY DUOTONE

CAPABILITIES (STANDARD WORK SURFACE)

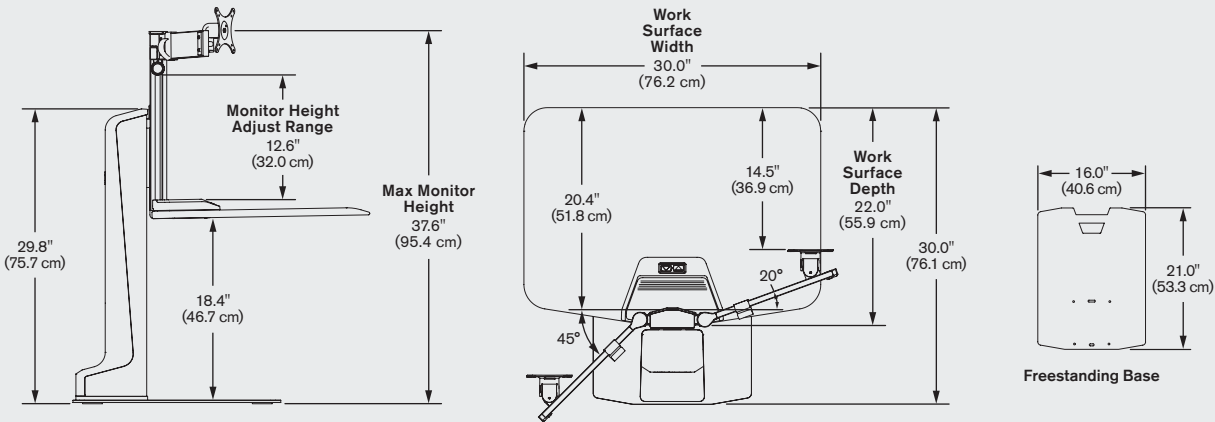



One Touch

The One Touch systems are electric powered sit-stand workstations that retrofit to your existing desk, making them compatible with any type of setup. Available in a range of models with various options, from freestanding to desk mounted.

One Touch Features



Electric Powered

Easily switch positions with just the push of a button. Provides the highest range of vertical travel on the market today at 20".

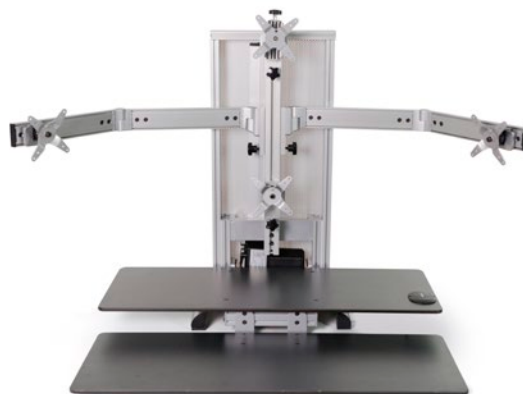

Fast Setup

Installs in less than 20 minutes on existing desk.

One Touch



One Touch Single Freestand List Price **\$1,886**

SPECIFICATIONS

- Height Adjustment Mechanism:** Electric
- Screen Size:** Up to 30"
- Weight Capacity:** Supports monitors up to 25 lbs, max weight of 100 lbs
- Height Adjustment:** 20"
- Mount Configurations:** Freestanding
- VESA Compatibility:** 75 & 100mm, adapter included
- Warranty:** 10 years unit/parts, 2 years motor

AVAILABLE MODELS

700-0-1328-1028-01
Upper surface: 13" x 28", Lower surface: 10" x 28"

FINISHES

SILVER

One Touch Dual Freestand List Price **\$2,047**

SPECIFICATIONS

- Height Adjustment Mechanism:** Electric
- Screen Size:** Up to 30"
- Weight Capacity:** Supports monitors up to 25 lbs, max weight of 100 lbs
- Height Adjustment:** 20"
- Mount Configurations:** Freestanding
- VESA Compatibility:** 75 & 100mm, adapters included
- Warranty:** 10 years unit/parts, 2 years motor

AVAILABLE MODELS

700-0-1328-1028-02
Upper surface: 13" x 28", Lower surface: 10" x 28"

FINISHES

SILVER



700-FCG-1336-1336-02
List Price **\$2,364**
700-FCG-1336-1736-02
List Price **\$2,385**

One Touch Dual Ultra

SPECIFICATIONS

Height Adjustment Mechanism: Electric
Screen Size: Up to 30"
Weight Capacity: Supports monitors up to 25 lbs, max weight of 100 lbs
Height Adjustment: 20"
Mount Configurations: Flush, Clamp, Grommet
VESA Compatibility: 75 & 100mm, adapters included
Warranty: 10 years unit/parts, 2 years motor

AVAILABLE MODELS

700-FCG-1336-1336-02
Upper surface: 13" x 36", Lower surface: 13" x 36"

700-FCG-1336-1736-02
Upper surface: 13" x 36", Lower surface: 17" x 36"

FINISHES

SILVER



700-FCG-1336-1336-03
List Price **\$2,469**
700-FCG-1336-1736-03
List Price **\$2,485**

One Touch Triple Ultra

SPECIFICATIONS

Height Adjustment Mechanism: Electric
Screen Size: Up to 24"
Weight Capacity: Supports monitors up to 25 lbs, max weight of 100 lbs
Height Adjustment: 20"
Mount Configurations: Flush, Clamp, Grommet
VESA Compatibility: 75 & 100mm, adapters included
Warranty: 10 years unit/parts, 2 years motor

AVAILABLE MODELS

700-FCG-1336-1336-03
Upper surface: 13" x 36", Lower surface: 13" x 36"

700-FCG-1336-1736-03
Upper surface: 13" x 36", Lower surface: 17" x 36"

FINISHES

SILVER

One Touch



700-FCG-1336-1336-04
List Price **\$2,616**
700-FCG-1336-1736-04
List Price **\$2,637**

One Touch Quad Ultra

SPECIFICATIONS

Height Adjustment Mechanism: Electric
Screen Size: Up to 19"
Weight Capacity: Supports monitors up to 25 lbs, max weight of 100 lbs
Height Adjustment: 20"
Mount Configurations: Flush, Clamp, Grommet
VESA Compatibility: 75 & 100mm, adapters included
Warranty: 10 years unit/parts, 2 years motor

AVAILABLE MODELS

700-FCG-1336-1336-04
Upper surface: 13" x 36", Lower surface: 13" x 36"

700-FCG-1336-1736-04
Upper surface: 13" x 36", Lower surface: 17" x 36"

FINISHES

SILVER



700-FCG-1336-1336-13
List Price **\$2,625**
700-FCG-1336-1736-13
List Price **\$2,648**

One Touch One over Three

SPECIFICATIONS

Height Adjustment Mechanism: Electric
Screen Size: Up to 24"
Weight Capacity: Supports monitors up to 25 lbs, max weight of 100 lbs
Height Adjustment: 20"
Mount Configurations: Flush, Clamp, Grommet
VESA Compatibility: 75 & 100mm, adapters included
Warranty: 10 years unit/parts, 2 years motor

AVAILABLE MODELS

700-FCG-1336-1336-13
Upper surface: 13" x 36", Lower surface: 13" x 36"

700-FCG-1336-1736-13
Upper surface: 13" x 36", Lower surface: 17" x 36"

FINISHES

SILVER



700-FCG-1336-1336-22
List Price **\$2,868**
700-FCG-1336-1736-22
List Price **\$2,890**

One Touch Two over Two

SPECIFICATIONS

Height Adjustment Mechanism: Electric
Screen Size: Up to 30"
Weight Capacity: Supports monitors up to 25 lbs, max weight of 100 lbs
Height Adjustment: 20"
Mount Configurations: Flush, Clamp, Grommet
VESA Compatibility: 75 & 100mm, adapters included
Warranty: 10 years unit/parts, 2 years motor

AVAILABLE MODELS

700-FCG-1336-1336-22
Upper surface: 13" x 36", Lower surface: 13" x 36"

700-FCG-1336-1736-22
Upper surface: 13" x 36", Lower surface: 17" x 36"

FINISHES

SILVER



700-FCG-1336-1336-33
List Price **\$3,167**
700-FCG-1336-1736-33
List Price **\$3,189**

One Touch Three over Three

SPECIFICATIONS

Height Adjustment Mechanism: Electric
Screen Size: Up to 24"
Weight Capacity: Supports monitors up to 25 lbs, max weight of 100 lbs
Height Adjustment: 20"
Mount Configurations: Flush, Clamp, Grommet
VESA Compatibility: 75 & 100mm, adapters included
Warranty: 10 years unit/parts, 2 years motor

AVAILABLE MODELS

700-FCG-1336-1336-33
Upper surface: 13" x 36", Lower surface: 13" x 36"

700-FCG-1336-1736-33
Upper surface: 13" x 36", Lower surface: 17" x 36"

FINISHES

SILVER

Accessories



WNST-MAT

Winston Mat

List Price **\$71**

FEATURES

- 3/4" thick durable foam delivers deep-cushion comfort.
- Bounce-back memory restores energy while standing.
- Durable, stain-resistant surface.
- Material: Commercial grade, heavy-duty polyurethane.



8472

Desk Edge Mount for Winston Workstation

List Price **\$132**

FEATURES

- Mount Winston Workstation to the edge of the desk.
- Desk edge mount supports up to a 3" maximum desk thickness.



8485

Thru-Desk Mount for Winston Workstation

List Price **\$58**

FEATURES

- Bolt Winston Workstation thru the desk.
- Thru-desk mount measures 8" long and 3" wide.
- Supports up to a 2" maximum desk thickness.



8501

Laptop Holder for Winston Workstation

List Price **\$337**

FEATURES

- Laptop holder kit includes an arm mount, laptop tray, and a 14" pole mount.
- Laptop holder easily attaches to the Winston Workstation beam, accommodating mobile users.





5501

Laptop Holder for Winston-E

List Price **\$65**

FEATURES

- Securely grips tablet or laptop, with quick attach and release.
- Adjustable clasps allow free access to jacks and ports.
- Easy installation, attaches to standard VESA adapter.



More than Just a Trend: Standing for Your Health

Excessive sitting is associated with a number of chronic diseases and conditions, including:



120-140

Americans are burning 120-140 less calories a day than 50 years ago.



66%

increase in cancer.



112%

increase in diabetes.



54%

increase in heart attacks.



49%

increase of a higher risk of mortality from all causes.



Comparison Chart



	Winston Desk <i>(pp 6-9)</i>	Winston Lift <i>(pp 10-13)</i>	Winston Workstation <i>(pp 14-19)</i>
Height Adjustment Mechanism	Pneumatic	Pneumatic	Pneumatic
Weight Capacity	Up to 35 lbs	Up to 25 lbs	Varies by model
Height Adjustment	13.0" / 13.5" ***	19.0"	17.1"
Color	Black	Flat White, Silver, Vista Black	Flat White, Silver, Vista Black
Dual Monitor Option	Yes	Yes	Yes
Multi-Monitor (3+)	No	No	Yes
Mount Configurations	Freestanding	Desk Edge	Freestanding, Desk Edge*, Thru-Desk*
Warranty	5 Years	5 Years	5 Years



Winston-E <i>(pp 20-23)</i>	One Touch <i>(pp 24-29)</i>
Electric	Electric
Up to 40 lbs	Up to 100 lbs total, up to 25 lbs per monitor
18.4"	20.0"
Gray Duotone	Silver
Yes	Yes
Yes	Yes
Freestanding	Freestanding**, Flush, Clamp, Rail
5 Years	10 years unit/parts, 2 years motor

* Sold separately.

** Only available on single and dual models.

*** Height adjustment for WNST-DESKCR-36 and WNST-DESK-42 is 13", WNST2-DESK-36 is 13.5".

Don't see what you need?

Innovative offers hundreds of flexible mounting solutions. Just a few of the many choices are shown here. Innovative also specializes in custom product configuration. Tap into our engineering and production resources for your technology mounting requirements.

Contact us today:

InnovativeWorkspaces.com

800.524.2744

The Innovative Advantage

For over 30 years, Innovative has been a leader in designing and manufacturing ergonomic, space-saving monitor arms and mounts for flat panel monitors, notebooks, and tablets. What began as a family-owned operation in 1986 has grown into a global company that is on cutting edge of ergonomic monitor arms, laptop mounts, and sit-stand solutions. The vast majority of Innovative's products are manufactured out of its headquarters in Easton, PA.



Customer Focus

Innovative's employees take pride in enhancing the way users interface with technology. Our experienced team of sales representatives, in-house engineering and prototyping resources enable us to work with you to find the right solution for your specifications. Call us today to speak with a representative about your project: 800.524.2744.



Quality

Innovative leads the way in exceptional quality by combining product performance with award winning design. Most products are tested to 30,000 cycles, far exceeding BIFMA industry standards. Innovative's mounting solutions are built to withstand the demands of today's office environment and most products are backed by a 10 year warranty.

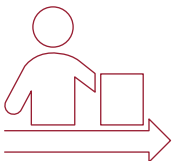

Designed + Assembled in USA

Innovative proudly designs and assembles a majority of our products in the USA. By designing our products onsite, Innovative is able to work closely with our customers from start to finish, providing them with a high quality product that meets their needs, has a high standard of performance and exceeds their expectations. Our in-house design team works on small to large quantity projects with highly configurable options.



Award-Winning Design

Innovative products have been recognized by such prestigious international design organizations as red dot and iF, as well as design competitions sponsored by Business Week, Contract and Buildings magazines.





HEADQUARTERS:

Innovative

100 Kuebler Road

Easton, PA 18040

United States

800.524.2744

InnovativeWorkspaces.com

Innovative Europe ApS

Center Boulevard 5

Copenhagen, 2300

Denmark

+45 469.490.79

sales@InnovativeWorkspaces.eu



[InnovativeWorkspaces](#)



[InnovativeUS_](#)



[InnovativeWorkspaces](#)



[InnovativeWorkspaces](#)